

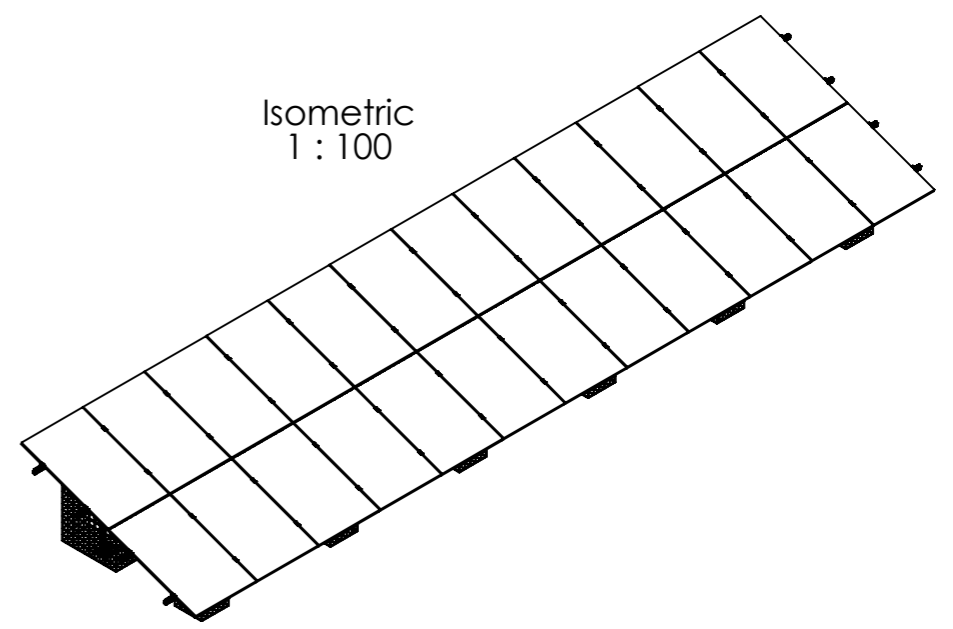

Acc. to the installation manual, the clamp position and the modules have to be installed in a symmetrical arrangement to the beam length.



24 modules (2x12 Portrait)
for module width ≤ 1144mm

20 modules (2x10 Portrait)
for module width 1144-1303mm

Peak velocity $q_p[z]$: 0.67kN/m²
Ground snow load S_k : 1.75kN/m²

	K2 Systems GmbH Haldenstr. 1 71272 Renningen Germany +49 7159 42059-0			Designation: Data sheet N-Rack 2.20 Gabion 2x12 S	
	Name	Date	Material:	Item no.:	A3
Designed	C. Erb	27.01.2026	-	-	All dimensions in mm
Approved	L. Kreemke	16.03.2026	Surface: -	Drawing no.:	
Last change			Weight: -	Scale: 1:50	Sheet 1 of 1

This drawing is the sole property of K2 Systems GmbH. It is protected by copyright and may only be copied, reproduced or distributed to a third party with explicit permission!

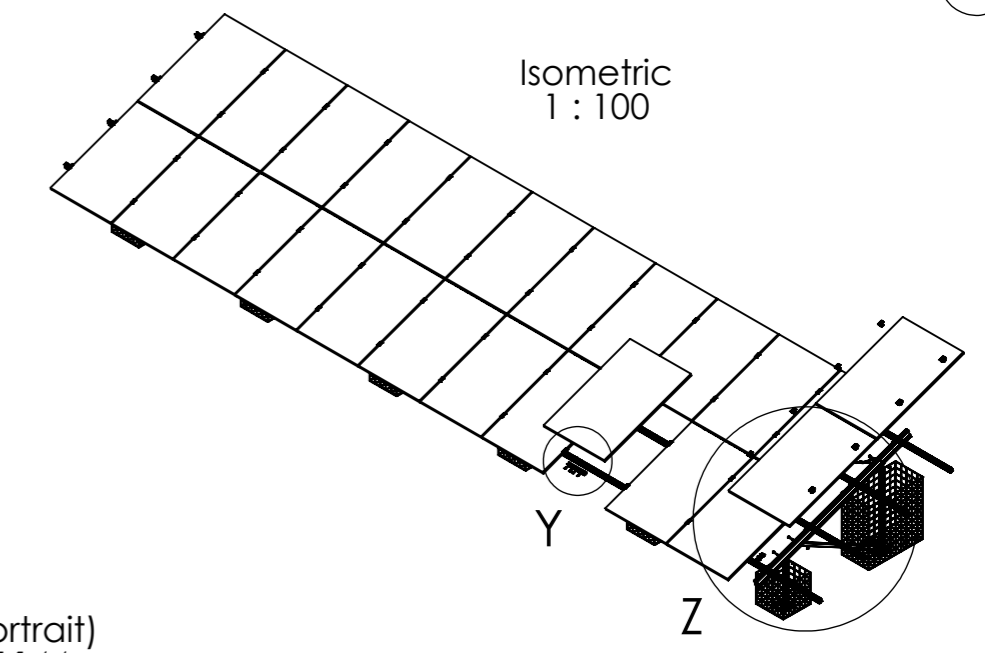
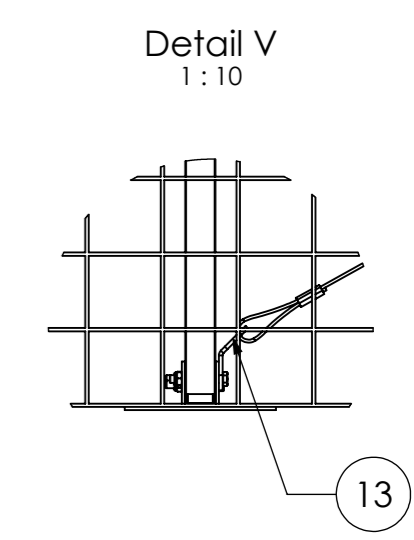
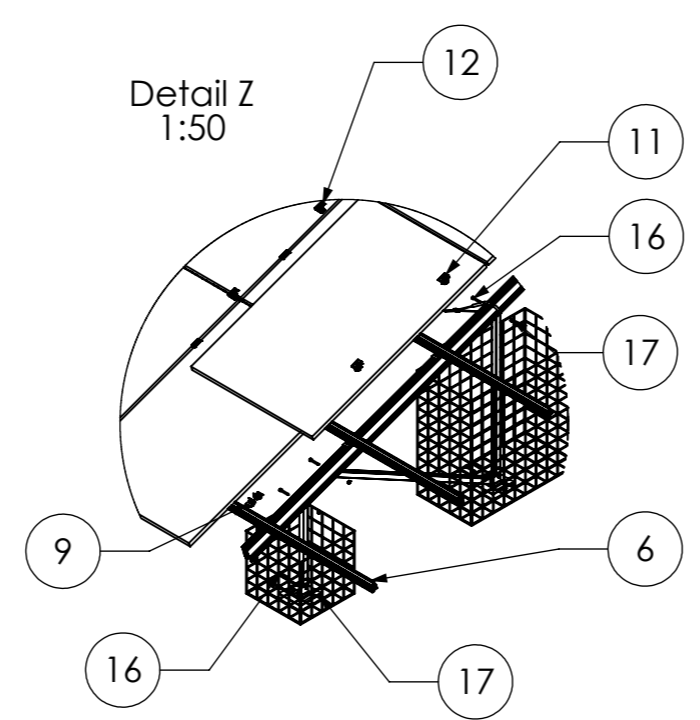
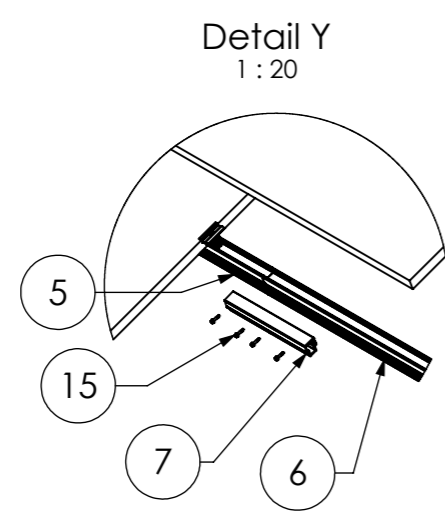
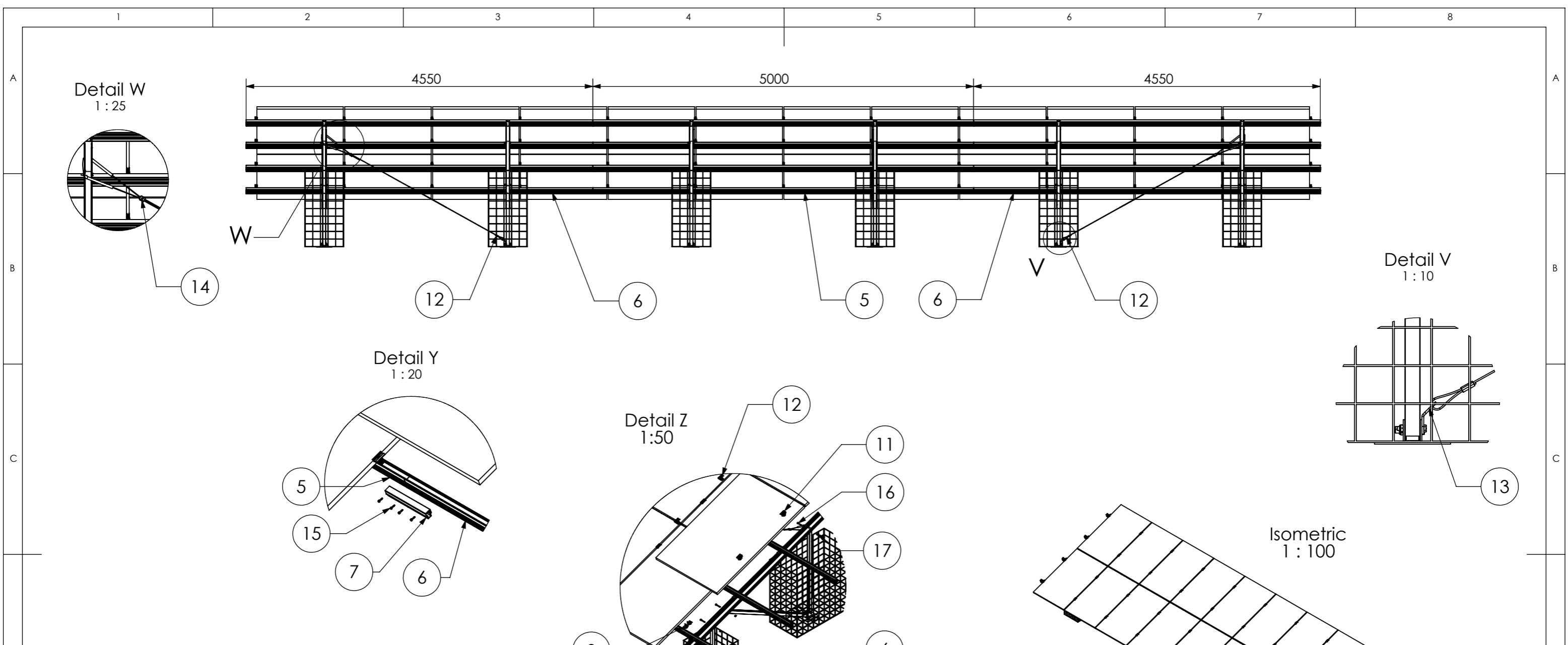

Pos.No.	Designation
1	Beam N-Rack 3020
2	3-Hole Brace N-Rack 715
3	3-Hole Brace N-Rack 1370
4	2-Hole Brace N-Rack 1696
5	CrossRail 73 - 5m
6	CrossRail 73 - 4,55m
7	CrossRail 73 Connector
8	N-Rack Base Plate
9	Climber 36/50 Set
10	EC Clamp Set
11	MC Clamp Set
12	Gripple Bracing
13	Gripple Angle
14	Gripple Lock
15	Self-tapping screw 5,5 x 25 - A2
16	Hexagon head bolt M10 x 70 ISO 4014 - A2-70
17	Hexagon nut M10 - DIN 985 - A2-70

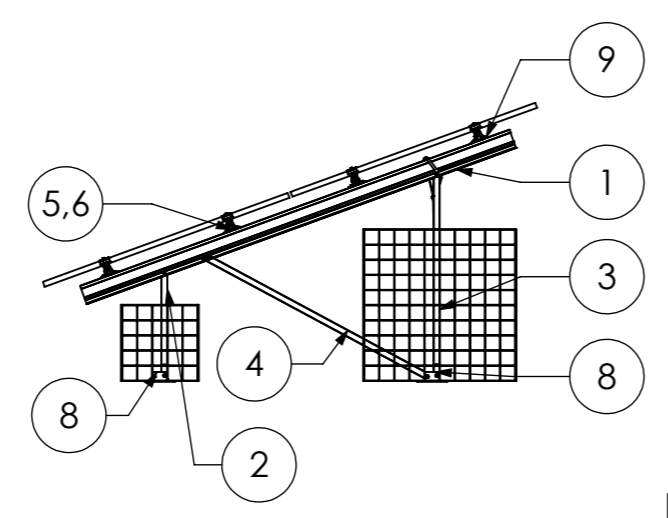

24 modules (2x12 Portrait)
for module width ≤ 1144mm

20 modules (2x10 Portrait)
for module width 1144-1303mm

Peak velocity $q_p[z]$: 0.67kN/m²
Ground snow load S_k : 1.75kN/m²

	K2 Systems GmbH Haldenstr. 1 71272 Renningen Germany +49 7159 42059-0			Designation: Data sheet N-Rack 2.20 Gabion 2x12 S																							
	<table border="1"> <tr><td>Name</td><td>C. Erb</td><td>Date</td><td>27.01.2026</td><td>Material:</td><td>-</td></tr> <tr><td>Designed</td><td></td><td></td><td></td><td>Surface:</td><td>-</td></tr> <tr><td>Approved</td><td>L. Kreemke</td><td></td><td>16.03.2026</td><td>Weight:</td><td>-</td></tr> <tr><td>Last change</td><td></td><td></td><td></td><td>Scale:</td><td>1:50</td></tr> </table>	Name	C. Erb	Date	27.01.2026	Material:	-	Designed				Surface:	-	Approved	L. Kreemke		16.03.2026	Weight:	-	Last change				Scale:	1:50	Item no.: -	Drawing no.: -
Name	C. Erb	Date	27.01.2026	Material:	-																						
Designed				Surface:	-																						
Approved	L. Kreemke		16.03.2026	Weight:	-																						
Last change				Scale:	1:50																						
This drawing is the sole property of K2 Systems GmbH. It is protected by copyright and may only be copied, reproduced or distributed to a third party with explicit permission!																											